



PACIFIC WOOD

Ph: (07) 3273 8555

Fax: (07) 3273 6844

E:sales@pacificwood.com.au

www.pacificwood.com.au

www.everlastkwila.com.au



Version 1b

"EVERLAST" Laminated Kwila Products Installation Guide

"Everlast" Finger Jointed Laminated Kwila products are manufactured to perform in applications where a combination of both **structural** and **visual** characteristics are required. "Everlast" Finger Jointed Laminated Kwila products are made exclusively with selected Kiln Dried (Moisture content less than 15%) Kwila (Intsia bijuga), which has a natural above ground durability rating of 1 (Effective life expectancy of 40 years+). "Everlast" Finger Jointed Laminated Kwila products use phenolic adhesives which are durable, heat proof, waterproof and chemical and fungal resistant. All laminated "Everlast" Kwila products including GL17S Beams, GL13 Posts and FJ Laminated Handrail products must be used in **above ground applications** and as with all timber products their performance in weather exposed applications is reliant on all parties including the specifiers, builders and homeowners following the recommendations outlined below;

On Site Handling

1. All "Everlast" beams, posts and handrails should be stored on evenly supported blocks or dunnage at least 100mm above ground allowing for good drainage and ventilation
2. All "Everlast" beams, posts and handrails should be kept dry by securely covering with a suitable weather proof plastic or tarpaulin
3. All "Everlast" beams, posts and handrails should be handled with care to ensure that the dressed finished surfaces are not damaged also they should not be dropped, jarred or dragged as this may adversely affect their performance

Design

1. Joint detailing, where possible, should follow the below principles;
 - Horizontal contact areas should be kept to a minimum in favour of self-draining vertical surfaces
 - Use only compatible fasteners that have adequate corrosion resistance and do not cause splitting when installed (eg stainless steel or hot dipped galvanized steel)
 - Wherever possible joint surfaces should be ventilated using spacers
 - Ensure that all joints have adequate drainage for any moisture that enters, so that moisture is not trapped in the joint
 - Make allowance for any thermal expansion and contraction in the joint design
2. The use of damp proof membranes is highly recommended where the product is in contact with porous materials like masonry and/or concrete
3. The use of rounded or arrised edges on all posts and beams is recommended, this reduces the chance of any coating failures on sharp square edges
4. All beams and posts should be installed with allowances for adequate ventilation and should be installed so that the moisture content within the product does not exceed 15% so that moisture gradients across the beam will not occur
5. The use of building overhangs, like eaves and/or other structures which protect the posts and/or beams from direct sun exposure and high levels of moisture movement is highly recommended
6. Shielding of the products in weather exposed applications is highly recommended by using metal, plastic or fibro to protect the products and keep them in a dry unstressed condition
7. GL17S joists and bearers in weather exposed applications should be installed with drip edges and end capping as per the below diagrams 1 and 2, columns and posts should also have appropriate drainage as per diagram 3. Exposed ends of GL13 posts must also have capping installed to prevent splitting on the end grain
8. Holes in GL17S beams for services should follow the below guidelines
 - Horizontal holes for fixing should follow the guidelines as per diagram 4
 - Holes should not be greater than 25mm diameter. If a hole is required with a diameter larger than 25mm, advice from a suitably qualified structural engineer is required
 - Service Holes should be restricted to the middle third of the beam span (Holes should not be greater than 25mm diameter)
 - Service Holes should be restricted to the middle third of the beam depth (Holes should not be greater than 25mm diameter)
 - If holes are required in any other area of the beam (eg near end supports) then advice from a suitably qualified structural engineer is required
 - Vertical holes for plumbing or electrical services are not recommended, advice from a suitably qualified structural engineer is required
9. Notches/Birds Mouthing can seriously reduce the strength of a GL17S beam, particularly if located in the tension zone. Notches/Birds Mouthing is not recommended, advice from a suitably qualified structural engineer is required
10. Beams should always be supported from the underside of the member, if installed butting up to the supporting structure then suitable framing brackets or custom made brackets should be used for all connections as per diagram 5
11. Allowance should be made on site that **ALL** surfaces of Beams, Posts and Handrails (including the end grain and any concealed joints) be primed/sealed and/or coated prior to installation

Coating

1. Painting – One coat of quality oil based primer is to be applied to all surfaces **prior** to the installation of the product
 - Acrylic – Exterior Solid Colour Acrylic Finish. One coat of oil based primer post installation followed by two coats of the exterior acrylic finish or otherwise as per the paint manufacturers recommendations
 - Oil Based – Exterior Solid Colour Oil Based Finish. One coat of oil based primer post installation followed by one coat of oil based undercoat followed by two coats of the exterior oil based finish or otherwise as per the paint manufacturers recommendations
2. Oiling/Staining - One coat of quality penetrating oil is to be applied to all surfaces **prior** to the installation of the product
 - Following installation 2 further coats of penetrating oil are required or otherwise as per the oil manufacturers recommendationsFurther to the initial coating an **ongoing inspection and maintenance programme** is essential. The inspections should focus on the level of exposure, all joints, fasteners, horizontal surfaces and end grain, as well as following any paint and/or oil manufacturers recommendations!

Additional Information

1. **Fire Resistance** – Kwila is naturally fire resistant and is suitable for use in fire rated buildings. Extensive fire test data also shows that large end section timber beams perform well in fire situations due to the formation of a protective layer of char. This charred area inhibits the effects of the fire on the inner portion of the timber beams, hence it maintains structural load support for measurable periods of time as the fire progresses. The glue used in the construction on the “Everlast” Beams is also resistant to fire, the gluelines will remain unaffected in the un-charred portion of the laminated beam.
2. **Termite Resistance** - Kwila is also naturally termite resistant, generally no additional chemical treatment is required.
3. **Extreme Weather Areas** – GL17S and GL13 products are **NOT** suitable for external applications in extreme weather areas such as Ski Resorts and Dry Desert Areas.
4. **Stainless Steel Wire Balustrade** – Where stainless steel wire balustrade is to be installed the following guidelines **MUST** be adhered too or all product guarantees will be void. Screw type fixings are **not** to be used, all fixings must be a bolt through type similar to the “Otter” Ezy Fix Balustrade System. For further information please contact your sales representative or hardware supplier.
5. **Surface Checking** – Surface Checking is where the timber fibres separate, normally across the growth rings, as a result of natural changes and variations in moisture content. Checks are often confused with delamination, where a glue bond has not fixed correctly, and the presence of wood fibre separation in the opening is a key distinguishing feature of checking! Opening as a result of the adhesive not bonding correctly generally appear as smooth surfaces possibly with the presence of dark and glossy adhesive residue. In general checks have negligible effect on the strength of the laminated product, however the reason for the checking should be determined and mitigation and remediation procedures put into effect! For further information on remediation please refer to “Glulam Repair Protocol – Wood Addiction 2010” available at www.pacificwood.com.au

Diagram 1

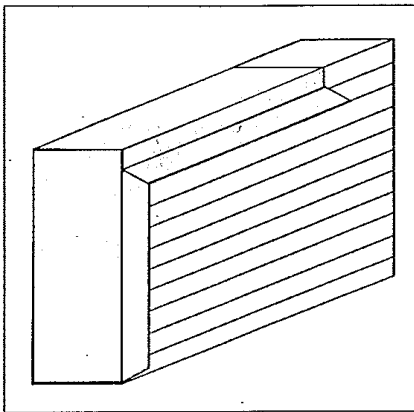

Diagram No. 1 - Illustration of Typical End

Diagram 2

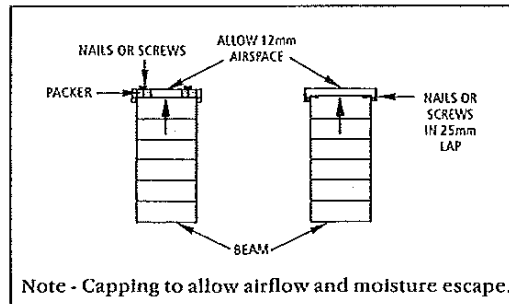

Diagram No. 2 - Capping Details

Diagram 3

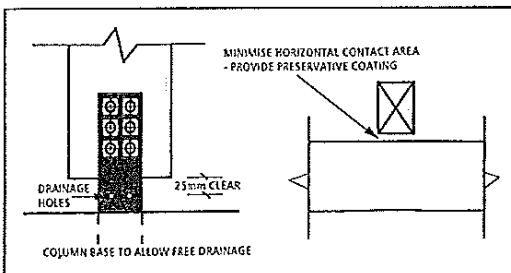

Diagram No. 3 - Detailing to avoid moisture traps

Diagram 4

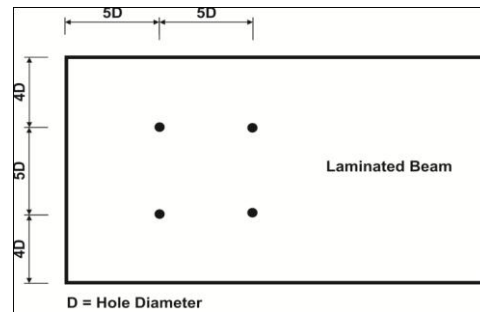

Diagram 4 - Horizontal Holes for Fixing

Diagram 5

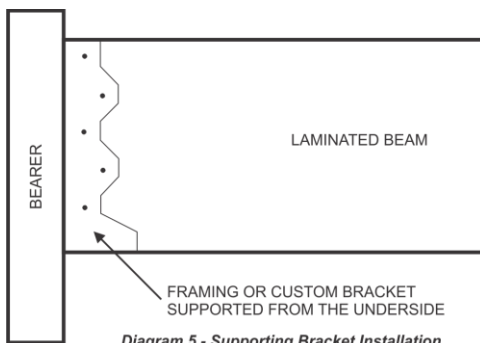

Diagram 5 - Supporting Bracket Installation



Glued Laminated Timber Association of Australia

References/Further Information

- GLTAA – Technical Data Sheet 1 – Handling/On-site Protection
- GLTAA – Technical Data Sheet 2 – Exposed Applications
- GLTAA – Technical Data Sheet 3 – Uniform Design Criteria
- GLTAA – Technical Data Sheet 4 – History of GL Grades
- GLTAA – Technical Data Sheet 5 – Epoxy Injection
- GLTAA – Technical Data Sheet 6 – Service Class 3 Applications
- Standards Australia and Standards New Zealand, AS/NZS 1328.2 *Glued Laminated Structural Timber – Part 1 Performance requirements and minimum production requirements*. SAI Global
- Glulam Repair Protocol – Wood Addiction 2010*